

FITTING INSTRUCTION

Clamp mark in acc. with		Cables joining
ISO	PN	
1	L	Left directional lights
2	+	Rear fog lights
3	31	Ground
4	R	Right directional lights
5	58R	Right side parking lights
6	54	Stoplights
7	58L	Left side parking lights

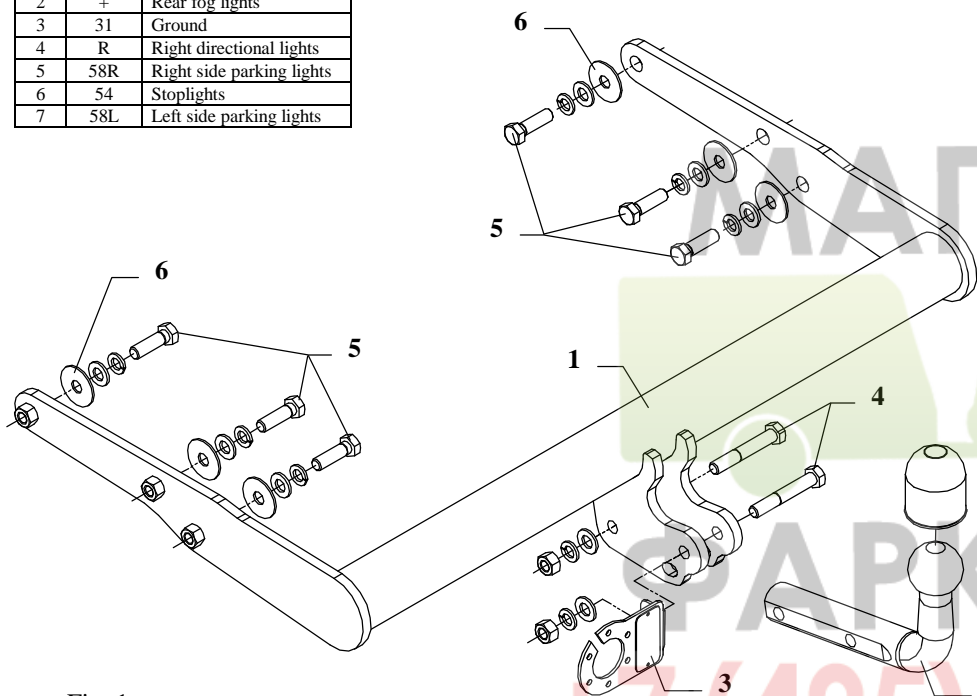

Fig. 1

This towbar is designed to assembly in following cars: **VOLKSWAGEN T5**, produced since 2003, catalogue no. **K42** and is prepared to tow trailers max total weight **2800 kg** and max vertical load **120 kg**.

From manufacturer

Thank you for buying our product. Their reliability has been confirmed in many tests. Reliability of towbar depends also on correct assembly and right operation. For this reasons we kindly ask to read carefully this instruction and apply to hints.

The towbar should be install in points described by a car producer.

The instruction of the assembly

1. To install our towbar one should disassemble a rear bumper with lights set.
2. Disassemble a metal reinforcement (not used any more).
3. Disassemble a plastic cover.
4. Slip the main bar of the towbar (pos. 1) to the chassis members in this way so holes in the towbar agree with original holes in the chassis members and fix using bolts M12x40mm (pos. 5). Use washers (pos. 6).
5. Fix tow-ball (pos. 2) with the socket plate (pos. 3) using bolts M12x75mm (pos. 4).
6. Tighten all bolts according to the torque shown in the table.
7. Reassemble a plastic cover and a bumper with lights set.
8. Connect electric wires of 7-poles socket according to the instruction of the car. (Recommend to make at authorized service station).
9. Complete paint layer damaged during installation.

Torque settings for nuts and bolts (8,8):	
M 8 - 25 Nm	M 10 - 55 Nm
M 12 - 85 Nm	M 14 - 135 Nm









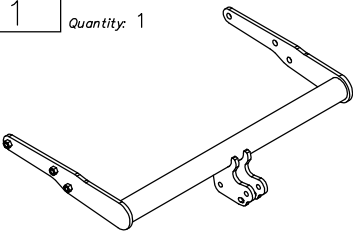

NOTE

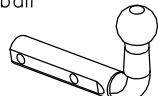
After install the towbar you should get adequate note in registration book (at authorised service station).The car should be equipped with:

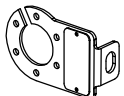
- Indicators
- Tow mirrors

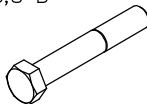
After 1000km check all bolts and nuts. The ball of towbar must be always kept clear and conserve with a grease.

Towbar accessories:

Pos. 1 Name: Main bar Quantity: 1	Pos. 5 Name: Bolt 8,8 B Quantity: 6 Dim. : M12x40mm
	
Pos. 2 Name: Tow ball Quantity: 1	Pos. 6 Name: Washer Quantity: 6 Dim. : Ø40xØ13x2mm
	
Pos. 3 Name: Socket plate Quantity: 1	Pos. 7 Name: Nut 8 B Quantity: 2 Dim. : M12
	
Pos. 4 Name: Bolt 8,8 B Quantity: 2 Dim. : M12x75mm	Pos. 8 Name: Plain washer Quantity: 8 Dim. : Ø 13 mm
	
Pos. 9 Name: Spring washer Quantity: 8 Dim. : Ø 12,2 mm	Pos. 10 Name: Ball cover Quantity: 1
	



PPUH AUTO-HAK S.J.

Produkcja Haków Holowniczych
Henryk & Zbigniew Nejman
76-200 SŁUPSK ul. Słoneczna 16K
tel/fax (059) 8-414-414; 8-414-413
e-mail: office@autohak.com.pl
www.autohak.com.pl

Towing hitch (without electrical set)

Class: **A50-X** Cat. no. **K42**

Designed for:

Manufacturer: **VOLKSWAGEN**

Model: **T5**

produced since 2003

Technical data:

D-value: 14,0 kN

maximum trailer weight: **2800 kg**

maximum vertical cup load: **120 kg**

Approval number acc. to regulations EKG/ONZ 55.01: E20-55R-01 0992

Foreword

This towbar is designed according to rules of safety traffic regulations. The towing hitch is a safety component and can be install only by qualified personnel. Any alteration or conversion of the towing hitch is prohibited and would lead to cancellation of design certification. Remove insulating compound and underseal from vehicle (if present) in the area of the matting surfaces of the towing hitch.

The vehicle manufacturer's specifications regarding trailer load and max. vertical cup load are decisive for driving, and values for the towing hitch cannot be exceeded.

D-value formula:

$$\frac{\text{Max trailer weight [kg]} \times \text{Max vehicle weight [kg]}}{\text{Max trailer weight [kg]} + \text{Max vehicle weight [kg]}} \times \frac{9,81}{1000} = D \text{ [kN]}$$